

Model no.:AVA-1100

Fit for screen size:32"-55"

Max loading weight:30kgs

Vesa:400x400

Supplied Parts and Hardware

A	M6*60 screws*1	
	M8*25 screws*3	
	8*1 washer*3	
B	M6*12 screws*13	
	Wrench*1	
C	M4 Wrench*1	
	M6 Wrench*1	
	M4*16 screws*4	
D	M5*16 screws*4	
	M6*25 screws*4	
	M8*25 screws*4	
	5*14 washer*4	
	M5*4 axle	
	M5*30*2	

01

Assembly Instructions for Trolley Stand

Safety warning: If you do not understand these directions, or have any doubts about safety of the installation, please call a qualified contractor. Check carefully to make sure there are no missing or defective parts. Never use defective parts. Improper installation may cause damage or serious injury. Do not use this product for any purpose that is not explicitly specified in this manual. We can not be liable for damage or injury caused by incorrect mounting, incorrect assembly or incorrect use.

Supplied Parts

NO.	Picture	Description	Quantity
1		square tube	2
2		tube connector	1
3		bottom pole	1
4		middle pole	1
5		top pole	1
6		pole connector	2
7		wheel	4
8		square plate	1
9		tv arm set	2
10		shelf	1
11		"C" clamp soft pad	1

Step 1 Attach the TV Brackets to your TV

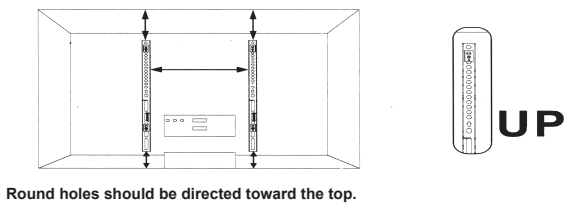

Round holes should be directed toward the top.

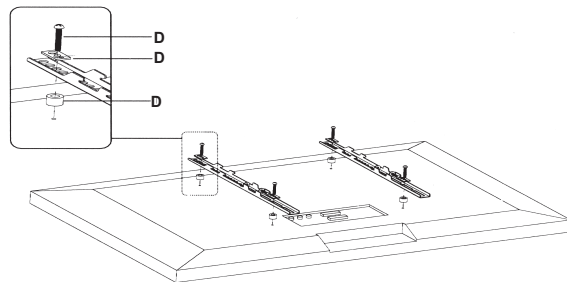

Add spacers in need to fit the bolt length and TV back.

03

Step 2 Install the Base

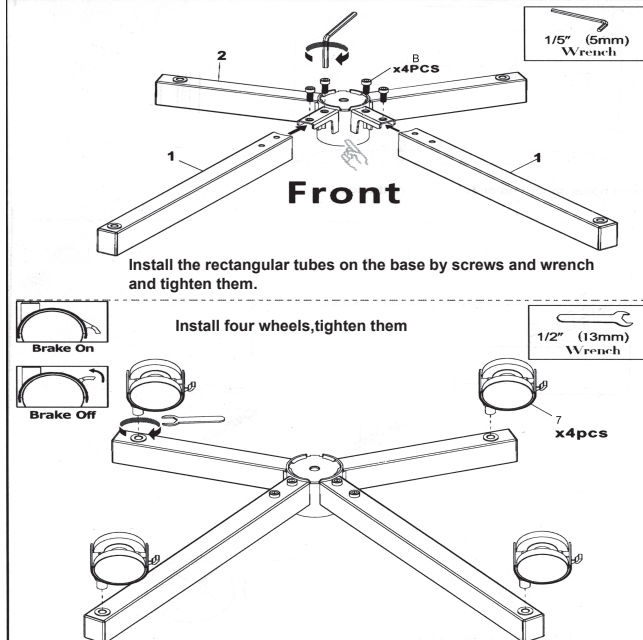

04

02

Step 3 Secure the Poles to the Base

3-1

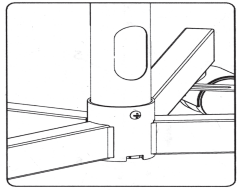

1 5" (5mm) Wrench

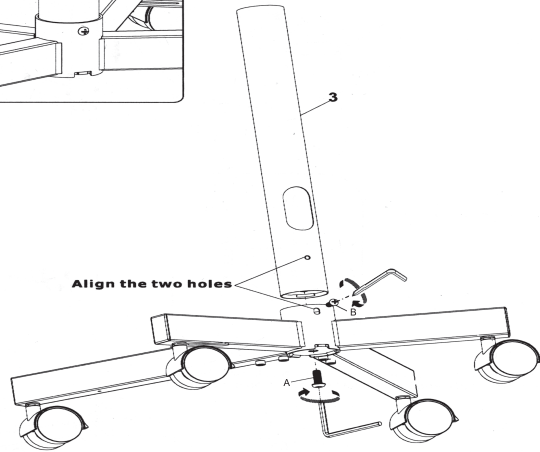

Insert the column into the base, first tighten screw(11) with a screwdriver, then tighten screw(10) with the wrench

05

3-2

Front

B

1 5" (5mm) Wrench

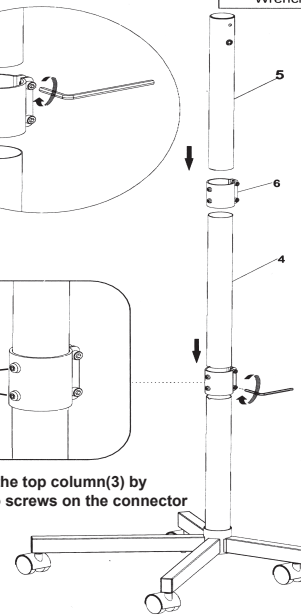

Connect the middle column(4) with the top column(3) by the connector(6), and tighten the two screws on the connector

06

Step 4 Secure the TV Plate to the Upper Pole

4-1

connect the plate and the top column, tighten the screws (13 & 12)

1 5" (5mm) Wrench

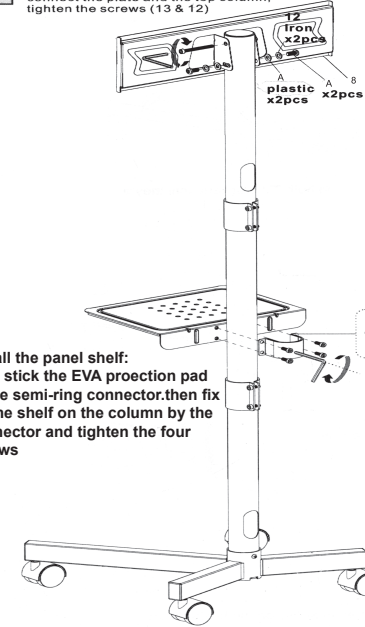

Install the panel shelf:

First stick the EVA proection pad to the semi-ring connector, then fix up the shelf on the column by the connector and tighten the four screws

Stick the EVA proection pad

07

Step 5 Hang the TV on the TV plate

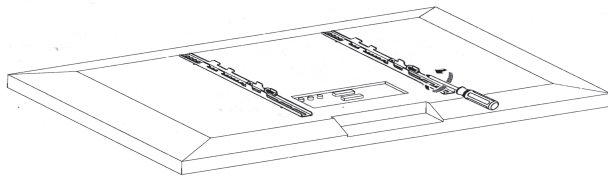

Slightly loosen the preassembled bolts on both TV brackets until they are seated flush with the plate.

HEAVY! You may need assistance with this step.

Phillips Screwdriver NOT included

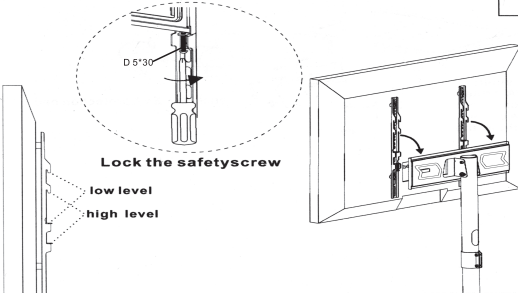

Lock the safety screw

low level
high level

Hang the TV on the TV Plate. Retighten the bolts on the brackets until they are pulled firmly against the TV plate.

08

Step 6 Adjust the Tilt Angle of the TV

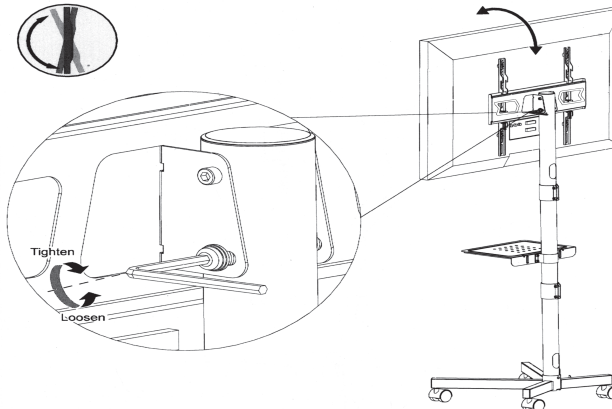

Slightly loosen nuts. Adjust the TV to your desired tilt angle. Retighten nuts to lock the tilt angle

Step 7 Adjust the Height of the Casters

1/2" (13mm) Wrench

If the TV cart is not level on the floor, you can adjust the casters by turning the preassembled nuts for proper stability.

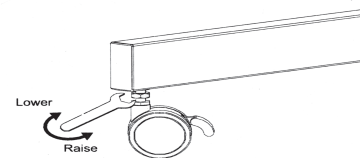

Lower
Raise

09

Step 8 Cable Management

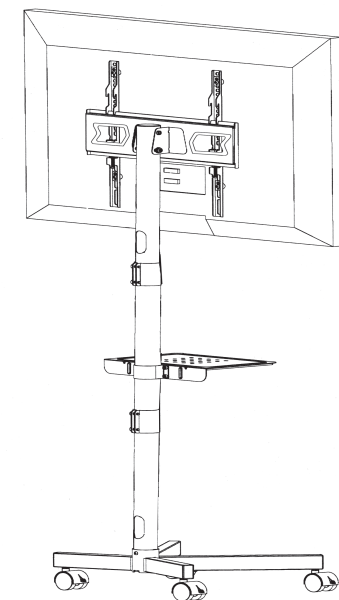

10